



HOW TO INSTALL... Cortex EPDM Membrane



www.obexuk.com

1

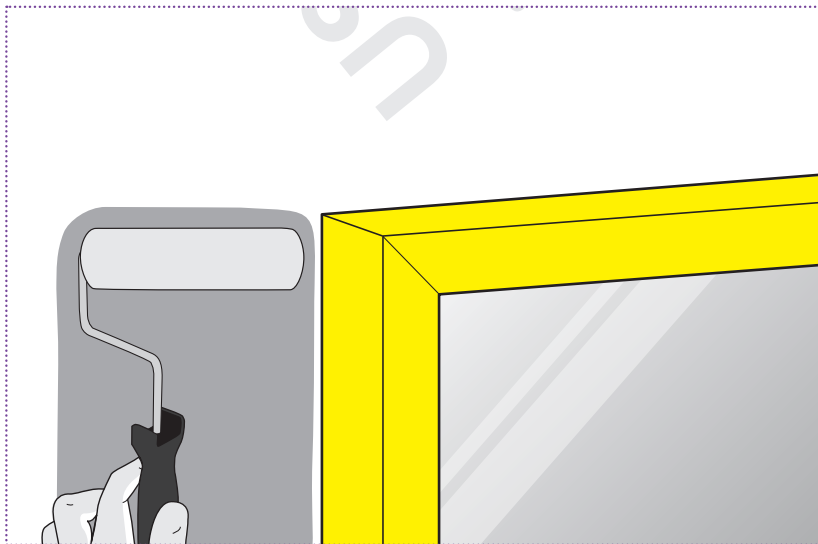

Ensure both substrates are clean, dry and free from grease and oil prior to application. Porous surfaces may need to be primed using Cortex 0785 Primer.

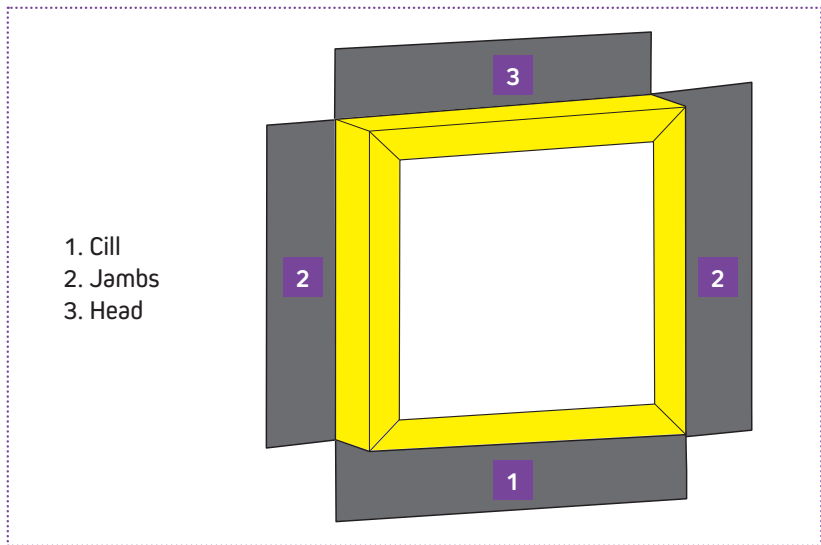

Cortex EPDM Membrane should be fitted in this order around the window:
Cill, Jambs and then Head.

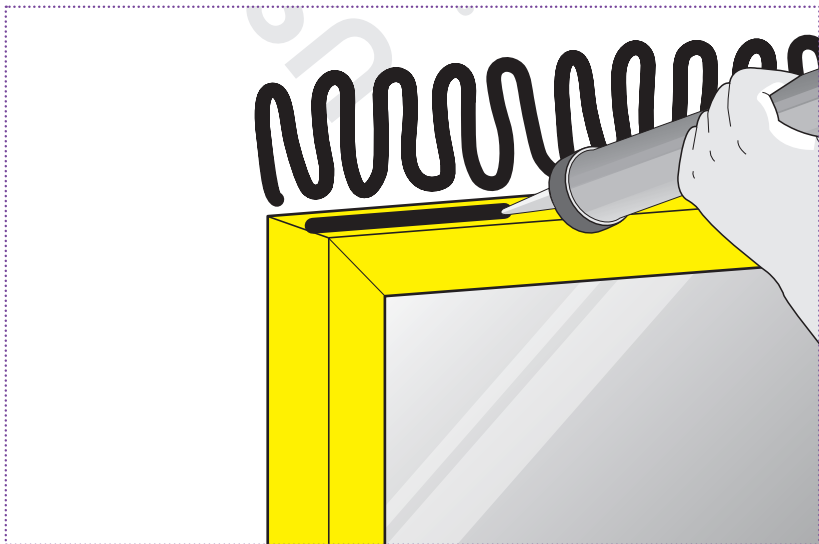

Apply Cortex Paste Adhesive to both the frame and the substrate using a paste adhesive gun.

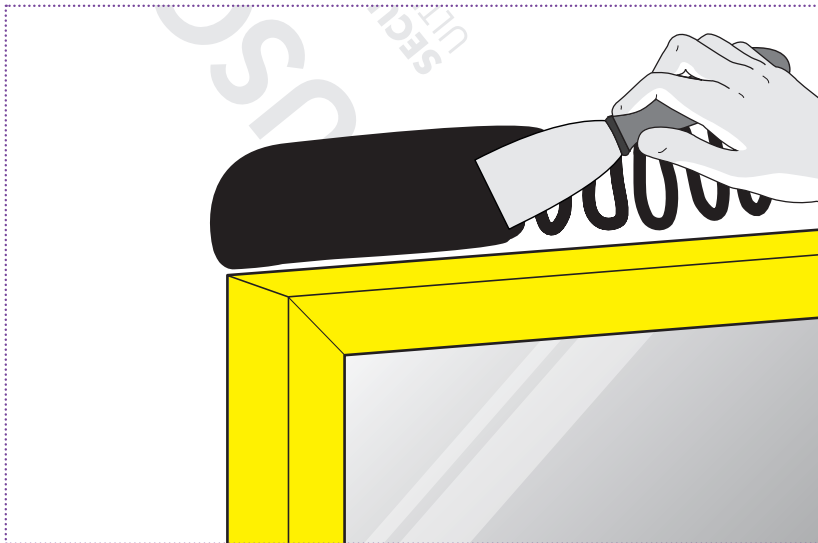

Spread out the paste adhesive using a paste adhesive spreader.



Bond the Cortex EPDM Membrane to the frame first, and then bond back to the substrate, ensuring the membrane is applied flat without creases.

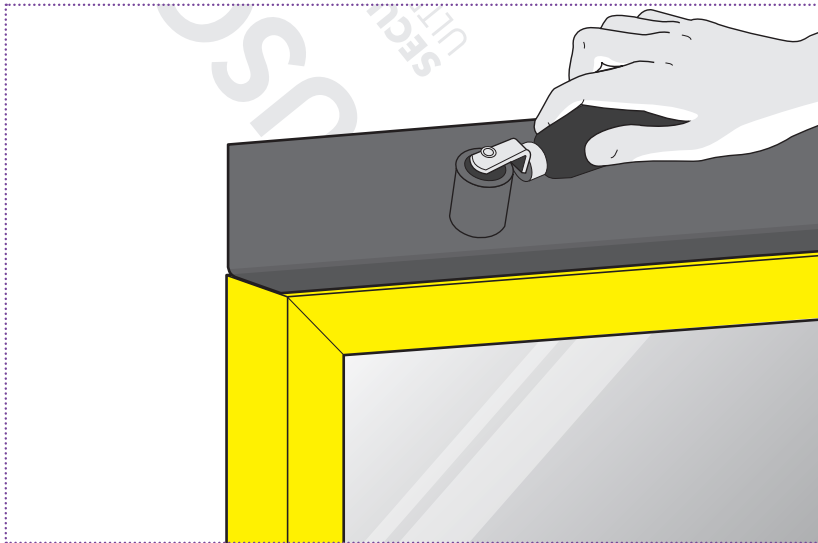

Roll firmly with a seam roller to ensure maximum bond on the frame and substrate.

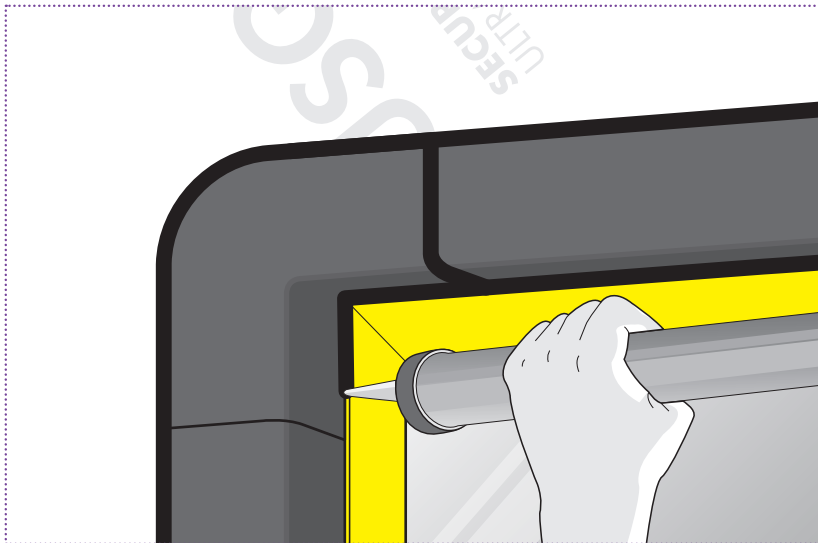

Corners can be sealed using Cortex 0901 External Corners. Apply a further bead of Cortex Paste Adhesive around the perimeter of the membrane and any joints/laps.



Tool off the paste adhesive with a spreader to ensure no open edges.

Tips

- » The width of the membrane must be designed with full consideration of the façade or window detail including the interior and exterior sides of the connection joint.
- » The recommended overlap between membranes and porous materials (concrete, brick) is a minimum 100mm. For non-porous material, we recommend at least a 20-30mm bond width.
- » Porous surfaces may need to be primed using Cortex 0785 Primer.
- » Cortex 0901 Corners can be used to provide a 100% watertight seal at corner junctions.



CORTEX[®]
EPDM membrane system



For technical assistance, call **01905 337800**, email sales@obexuk.com
or visit www.obexuk.com